

PN

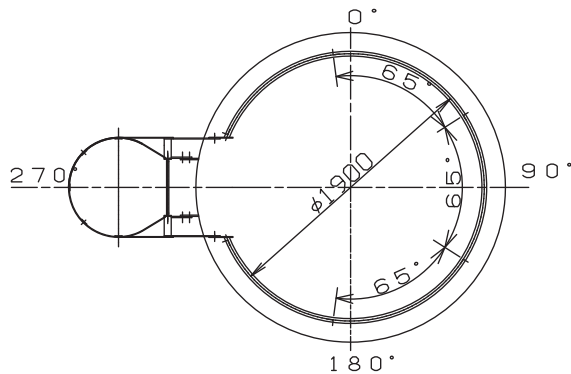
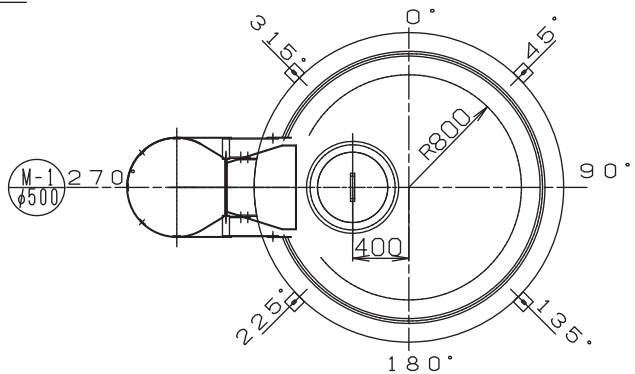

No.	DATE	MARK	REVISION	DES' DBY

NOZZLES

No.	NAME	SIZE	TYPE	NOTE
N-1				
N-2				
N-3				
N-4				
N-5				
N-6				
N-7				
N-8				
N-9				
N-10				
M-1	MAN WAY	φ500		

SPECIFICATION

NAME	
SIZE	φ 2200 x H2400
CAPACITY	9 m <sup>3</sup>
MATERIAL	FRP

DESIGN CONDITION

CHEMICAL	
DENSITY	
SPECIFIC GRAVITY	
DESIGN TEMP.	
DESIGN PRESS.	

NOTE

1. NOZZLE PROJECTION WITHOUT SHOWING MEASURE TANK ALL 100mm
2. B. N. W. SUS304
3. GASKET: E. P. I
4. VESSEL INSIDE: DISPOSE OF NO. OIL

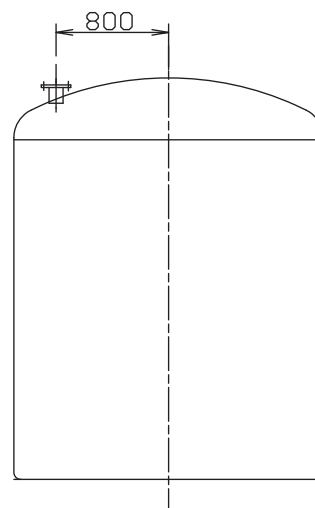
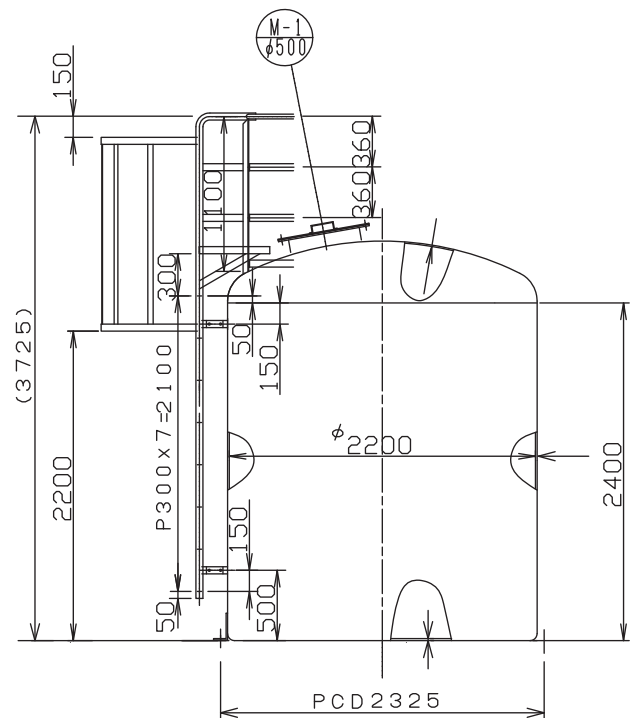

FOR			
CUSTOMER			
TITLE 9m <sup>3</sup> of a standard			
DATE	SCALE	CHECKED BY	DRAWN BY
	1 / 40		
DWG. NO.	NO. REQD		
CBSTE9	1		



CHUO BOSHOKU KOGYO CO.,LTD